



**URANY**  
TU ALIADO EN CONTROL DE MOVIMIENTO

# Soluciones en Automatización

Más de 20 años de experiencia...

[www.urany.net](http://www.urany.net)

## OFICINA PRINCIPAL



Distribuidor de 12 Marcas  
de Nivel Global





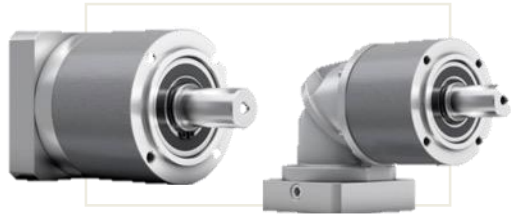

✓ STOCK

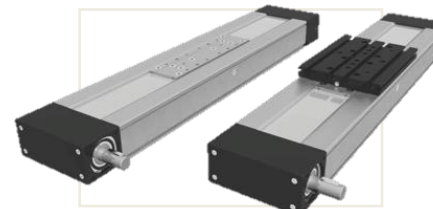

✓ STOCK

**mayr**<sup>®</sup>



✓ STOCK

**LinMot**<sup>®</sup>



**EDRIVE**<sup>™</sup>

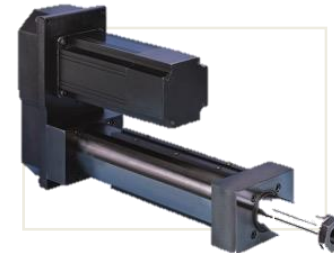

**JOYCE**<sup>®</sup>



**MTS**<sup>®</sup>  
SENSORS



**DISTRIBUCIÓN MAESTRA DE 12 MARCAS**

Tu aliado en control de movimiento.

**WON**

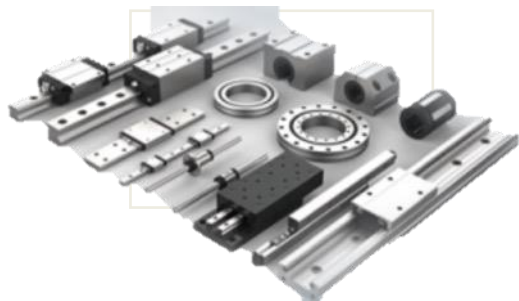

**id** TECHNOLOGY FOR TOMORROW  
**ITOHO DENKI**



**GLIDE-LINE**



**DISTRIBUCIÓN MAESTRA DE 12 MARCAS**

Tu aliado en control de movimiento.

# RODILLOS MOTRICES

**Establecido en 1946**

Por mas de 70 años ha desarrollado soluciones avanzadas para el manejo de materiales.

**D&D**

Gran inversión en diseño y desarrollo para ofrecer nuevos productos que cubran las necesidades de la industria

**Líder a nivel mundial**

El único fabricante de rodillos totalmente autónomo en el mundo, con experiencia desde la mecánica hasta la logística

**Control**

Productos con un riguroso sistema de control de calidad que se apega a la norma ISO9001

**Compromiso ambiental**

Certificación ISO14001  
Bajo consumo de energía  
Materiales limpios y reciclables

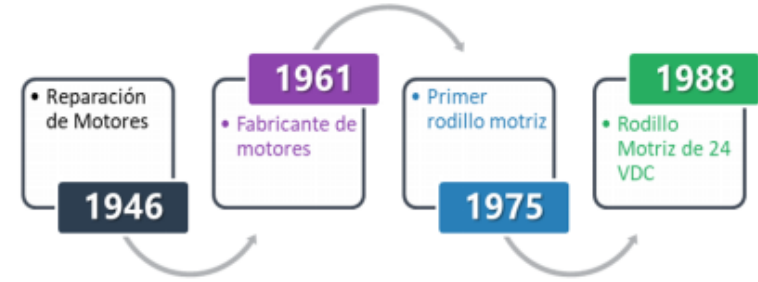

## ¿Qué son?

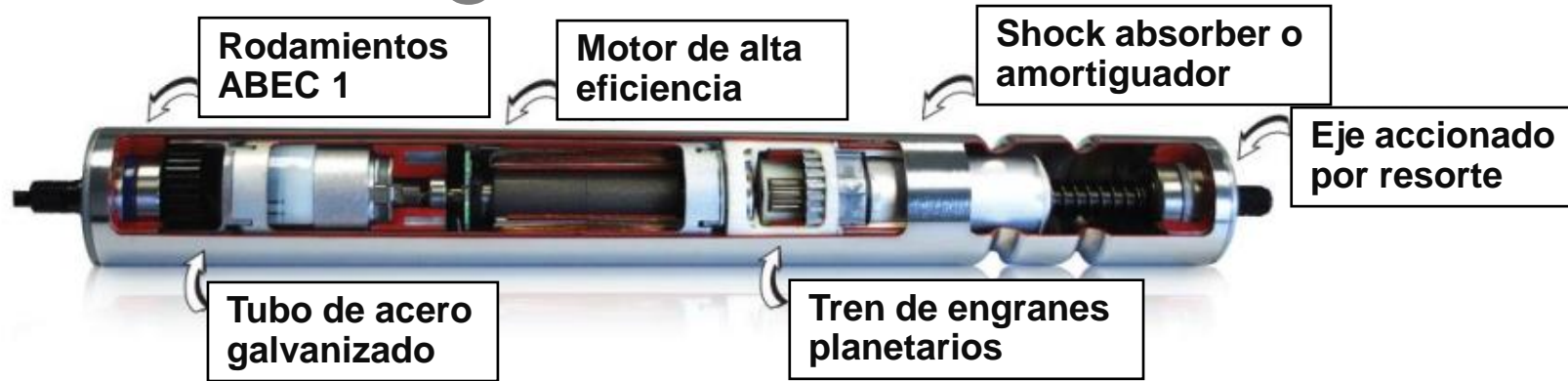

## Características

- **Motor DC 24V**
- **Etapa de reducción**
- **Electronica de control interna o separada**
- **Shock absorber**

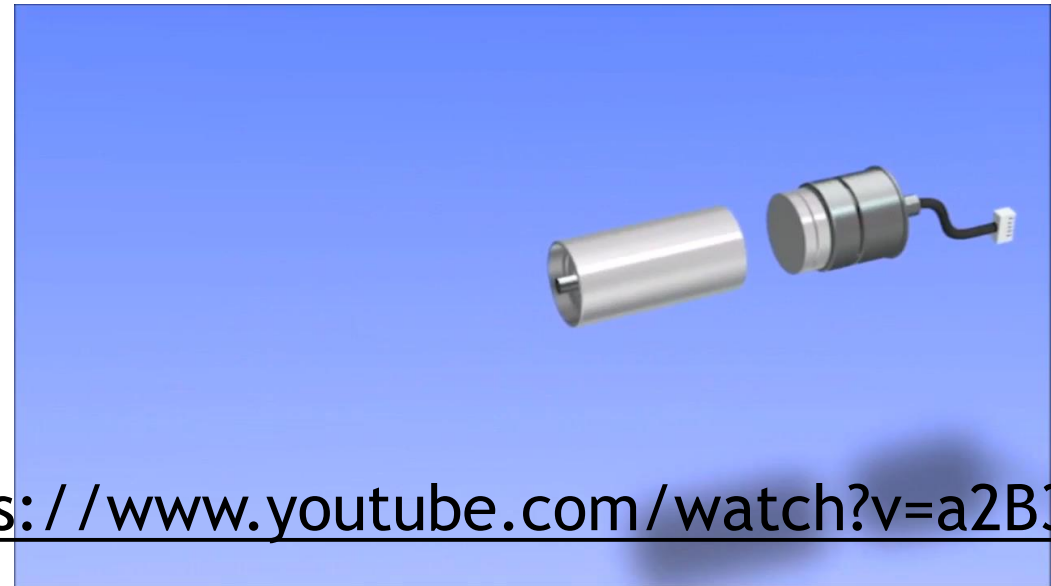

<https://www.youtube.com/watch?v=a2B3s-639C8>



# RODILLOS MOTRICES

## Ventajas

- Ahorro de espacio
- Seguros y fáciles de limpiar
- Libres de mantenimiento
- Ahorro de energía
- Configurable
- Fácil Instalación



 Ready to connect

<http://www.itoh-denki.com/es/productos/gama>



## Gama de productos

- **Controles**



- **Rodillos motorizados**
- **Módulos de transferencia**

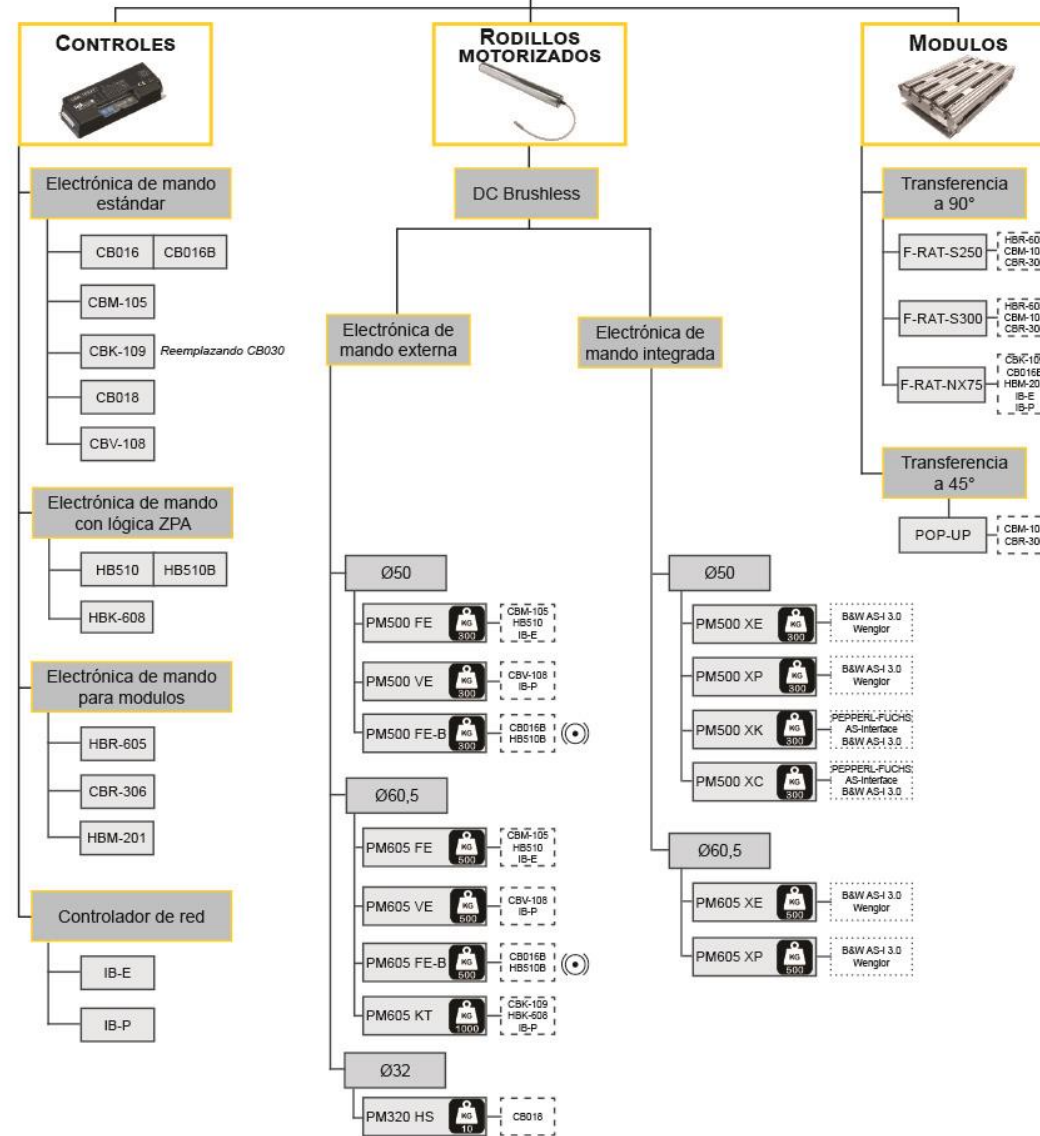

  Electrónica de mando asociada    
   Módulos / sensores compatibles    
 Carga max a transportar con arreglo a la velocidad    
 Versión freno mecánico

# RODILLOS MOTRICES

## Topología de control

Hasta 2 rodillos

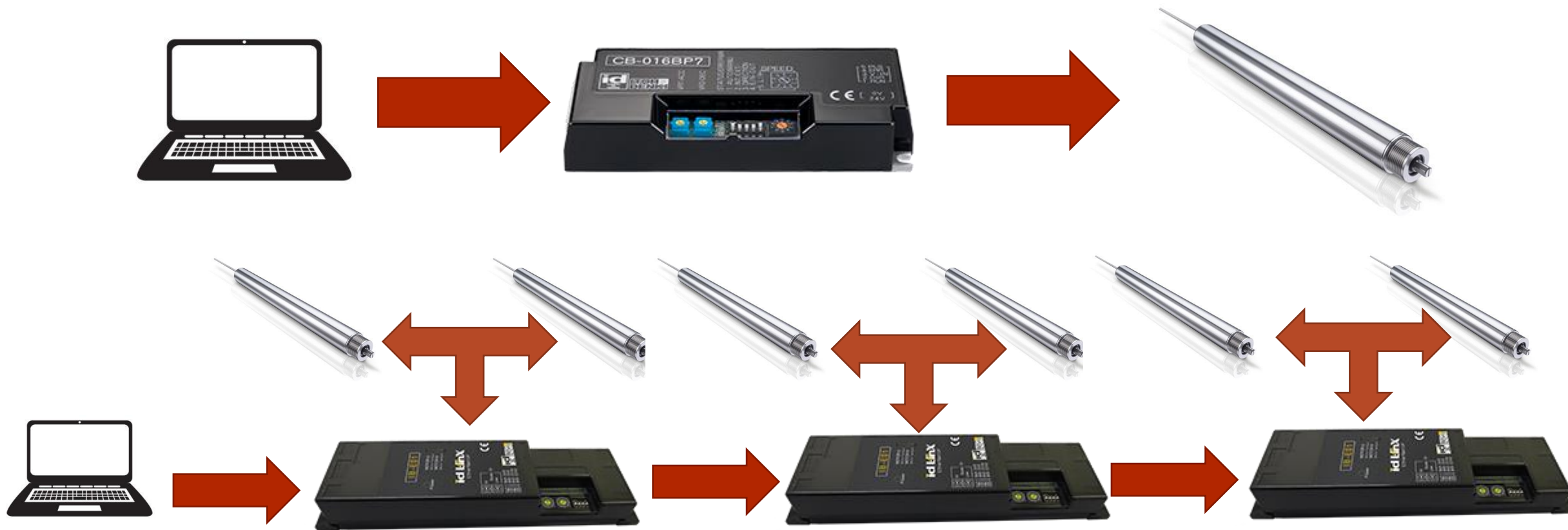

# RODILLOS MOTRICES

## Factores que definen la selección

- Material del producto
- Peso/dimensiones del producto
- Velocidad de transportación deseada
- Orientación
- Diámetro del rodillo
- Voltaje disponible



Light	Standard	Heavy
   HS	   FE    FE-B With mechanical brake    VE    VE	   VE    VE
   KT		

Standard	With ZPA	Network controller
CB-018		
CBM-105	HB-510	EtherNet/IP IB-E03
CB-016B	HB-510B	EtherNet/IP IB-E03B
CBV-108		PROFI NET IB-P01 IB-P03
CBK-109	HBK-608	EtherNet/IP IB-E04

# RODILLOS MOTORIZADOS

## Rangos Capacidad / Velocidad

Diámetros Estándar:

- 32mm
- 48.6mm
- 50mm
- 57mm
- 60.5mm

- Largo Máximo hasta 1000mm ( $\Delta$ 1mm)
- Capacidad de hasta 1,000 Kg
- Velocidades de 4 m/min hasta 79 m/min
- Temperatura ambiente de funcionamiento: -30° a 40° C.

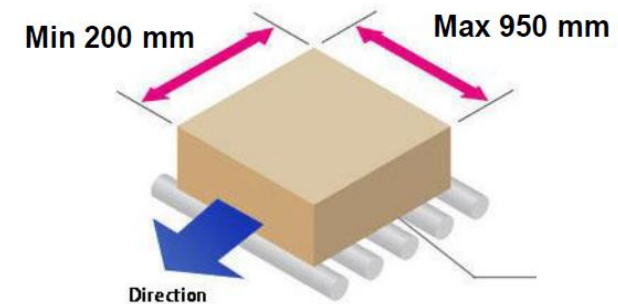

# RODILLOS MOTORIZADOS

## Opciones de Rodillos

Rodillos Motrices para Transportadores de Banda Modular

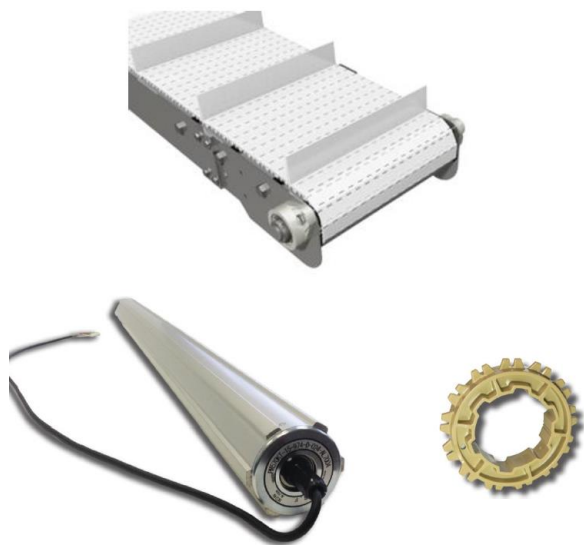

Rodillos Motrices para Transportar Pallets



Rodillos a Prueba de Agua



<https://www.youtube.com/watch?v=e8D5QkBHly8>

## Opciones Personalizadas



Recubrimientos



Clutch



Sellos adicionales para alta humedad



Frenos



<https://www.youtube.com/watch?v=4m3EPGFK-Wo>

ITOH DENKI

## MODULOS DE TRASFERENCIA

ITOH DENKI CO.,LTD.

Module

Flat-Right angle Transfer

# F-RAT

Neo-CrossOver

NX series

Alto rendimiento en “Módulos en ángulo recto” para la industria con altos estándares de seguridad y bajo costo de mantenimiento.

Diseño avanzado

**50 kg**  
Carga máxima

**2,250**  
cajas-hora rendimiento

**75 mm**  
entre centro de rodillos desviadores

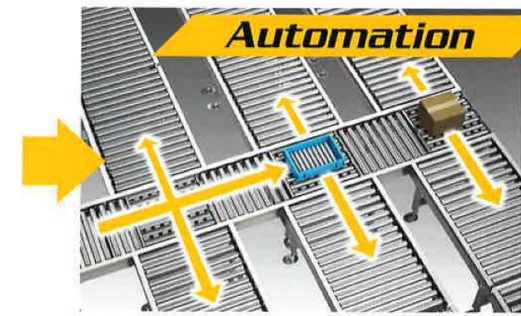
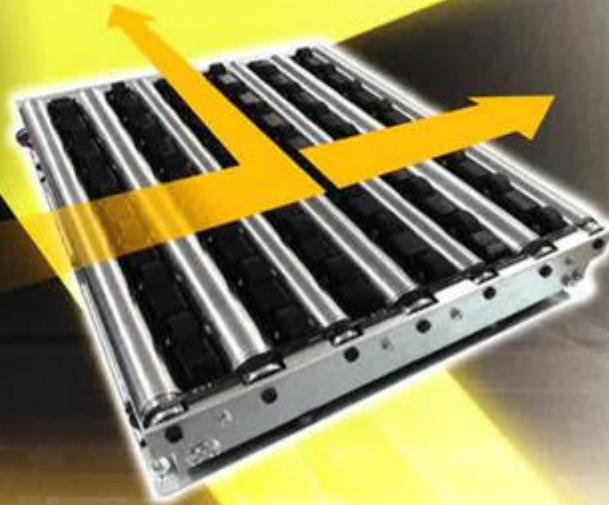

- Operados con 24 VDC
- No contienen sistemas neumáticos
- Velocidades de Operación de hasta 60 m/min
- Distancia máxima:

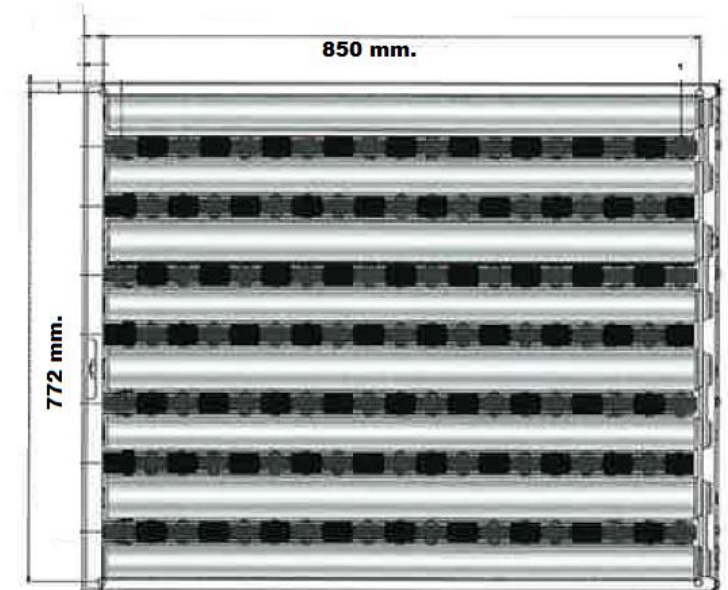



ITOH DENKI

# MODULOS DE TRASFERENCIA

Slide Open Gate Module

# SOG



Copyright ITOH DENKI CO.,LTD. All rights reserved.

Mantiene el movimiento lineal fácil y seguro



Presiona un boton para abrir o cerrar (5 s.)  
"Modo Automatico" por sensor de movimiento o  
"Modo manual" al presionar un botón pueden ser  
seleccionados.

Establezca duración de  
apertura/cierre mediante el PLC  
para modo automático.

24 VDC

Hasta 30 kg. De capacidad

ITOH DENKI CO.,LTD.

Module



<https://www.youtube.com/watch?v=oolutr5qu0I>

# SOLUCIONES PARA LA INDUSTRIA

Applications motorized rollers Powermoller®

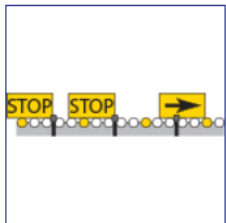

Zero pressure accumulation (ZPA)

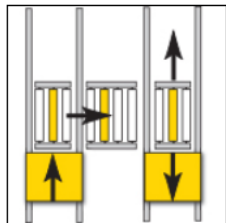

90° transfer

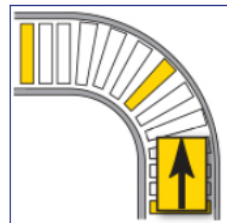

Curve

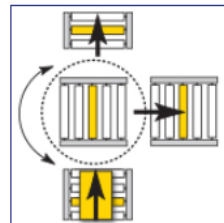

Turn table

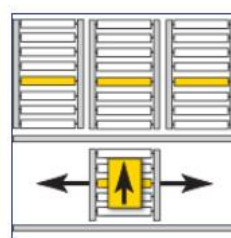

Cross transfer

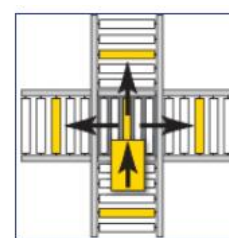

Multidirectional transfer

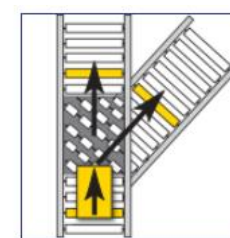

30°/45° transfer

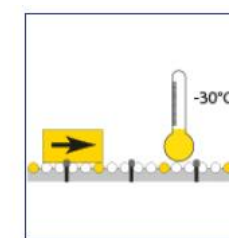

Cold room

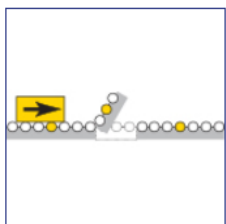

Gate

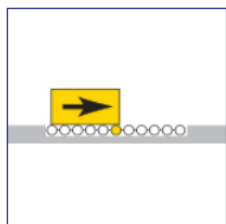

Floor conveyor

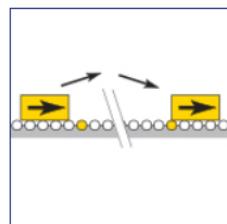

Acceleration / Deceleration

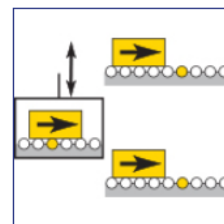

Lift

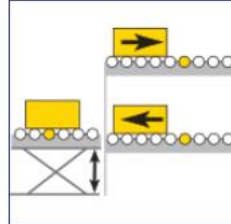

Lifting table

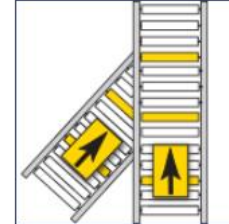

Bifurcation / Merge

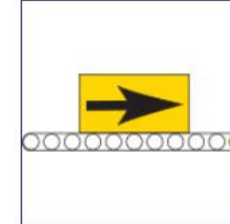

Belt conveyor

# SOLUCIONES PARA LA INDUSTRIA

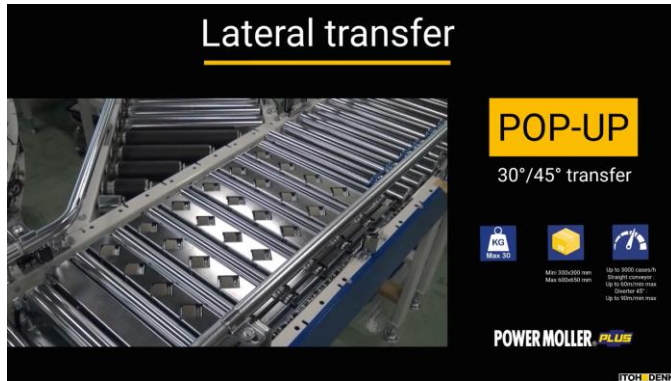

[https://www.youtube.com/watch?v=ypPSvbdHZ\\_k](https://www.youtube.com/watch?v=ypPSvbdHZ_k)

<https://www.youtube.com/watch?v=aAVmFZN4WXE&t=38s>

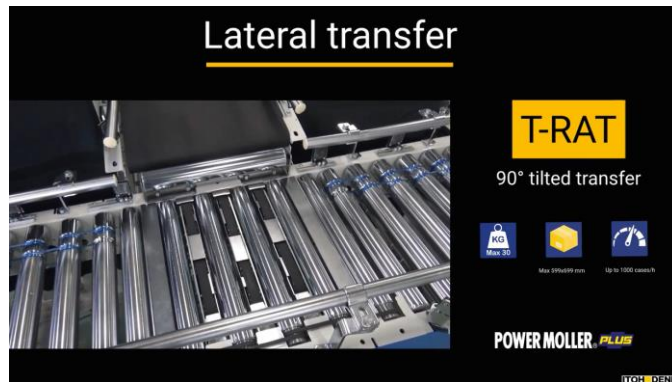

**Providing the most innovative industries with high quality solutions for conveyors**

ITOH DENKI



PRODUCTOS RECOMENDADOS

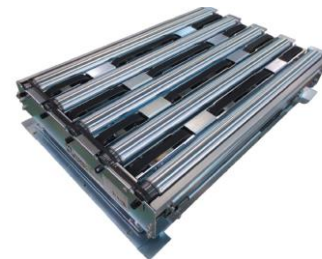

FORTALEZAS

# Compatibilidad



SIEMENS



OMRON

Rockwell  
Automation



FESTO



YASKAWA

rexroth

Entre otras...

FORTALEZAS

# Software de Cálculo

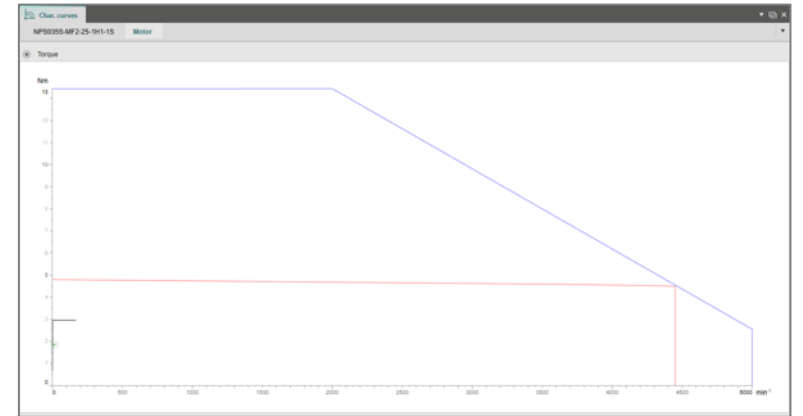
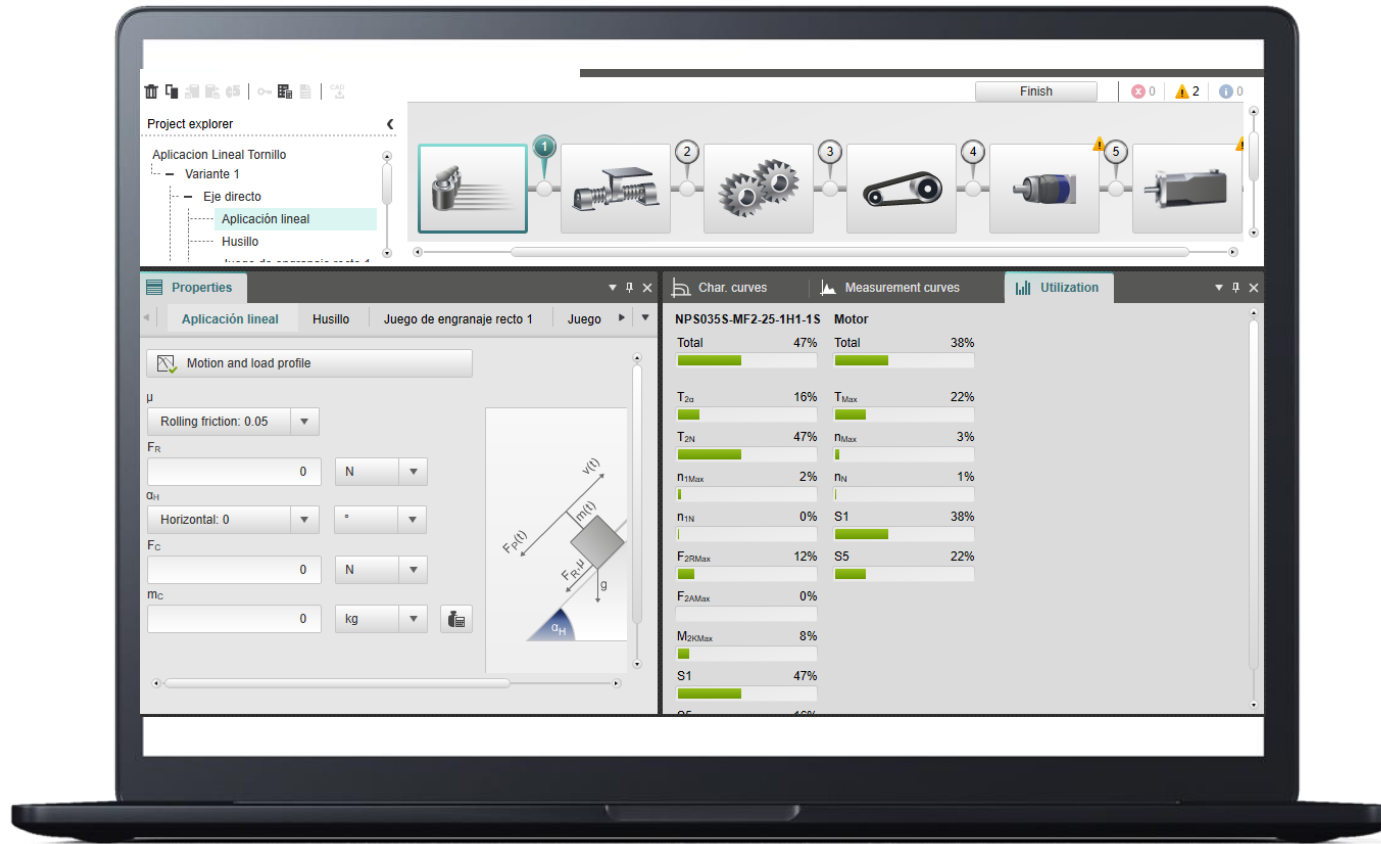

FORTALEZAS

# Amplio Stock



UNIMOTION



¡Gracias por su atención!

## Corporativo Querétaro

Tel. (442) 220 9089

[mercadotecnia@urany.net](mailto:mercadotecnia@urany.net)

[www.urany.net](http://www.urany.net)

**URANY**  
TU ALIADO EN CONTROL DE MOVIMIENTO